

CHESHIRE
mouldings
TRADE

**Core Deck
American
Range**
Fitting
Instructions

DESIGNED BY
**EASY
INSTALLATION**
FITTERS FOR

Important Information

The following instructions are for installing the Cheshire Mouldings **Core Deck American softwood decking system**.

Cheshire Mouldings **Core Deck American softwood system** is suitable for **ground level decks and decks up to 600mm** above ground level.

Maximum distance between posts is **1800mm**.

Cheshire Mouldings Core Deck system has been independently tested by FIRA and when installed in accordance with these instructions, conforms with Building Regulations for balustrades at 900mm (min) high and 0.36KN/m domestic loadings.

As only official Cheshire Mouldings parts have been tested, the use of non Cheshire Mouldings products used in conjunction with this system cannot be guaranteed to conform.

All components should be inspected BEFORE installation commences for any damage and to check all your items are correct before installation. While care is taken to match our engineered timber products, timber is a natural product where the colour, grain structure, can vary.

While we do everything possible to ensure the information contained within these fitting instructions are correct, they are only a general guide, every situation is different. Please read through the fitting instruction fully before commencing any fitting, Cheshire Mouldings will not be held responsible for any mistakes made through incorrect fitting. You will need to take extra care when installing pre-finished components and some touching up will undoubtedly be necessary around the cut areas.

If you have any queries please contact our technical helpline on **(0800) 085 3475**.

Please note:

All components should be inspected BEFORE installation commences for any damage, as Cheshire Mouldings cannot be held responsible for any damage caused during installation.

Tools required:

Saw, Battery drill, pozi-drive bit, drill bits $\varnothing 3\text{mm}$ & $\varnothing 4\text{mm}$, hammer, g clamps, chisel, spirit level, tape measure.

Fitting Instructions

Installing Posts

To establish correct height and length for the posts, measure down 1050mm from top of the post if you are using a plain square post or from under the decorative feature if you are using post with integrated cap. Mark the post. This indicates top of deck board location (**Fig.1**).

Posts should be positioned 1800mm max between inside faces (**Fig.2**).

Secure your post at the correct height with 100mm landscape screws by either positioning the posts inside the joists so that 2 post faces can be secured through 2 joists at 90° (**Fig.3**). If this is not possible, posts that are fitted to the outside of the joists should be half lapped to the height of the joist and deck board thickness and rebate any corner posts if the balustrade has a 90° turn (**Fig.4**).

Handrails

With posts secured, re-measure distance between inside post faces. Please allow for bracket thickness of 3mm per bracket. Trim top and bottom rails to length. To install bottom rail, offer rail hanger brackets to each end of the rail. Pilot drill through back bracket holes and secure with screws supplied (**Fig.5**).

Place 2 x 40mm blocks onto top of deck boards and offer bottom rail assembly between posts and onto top of blocks (**Fig.6**).

Check that the brackets are central to the inside post faces. Pilot drill through the side bracket holes and fix to post using screws supplied (**Fig.7**).

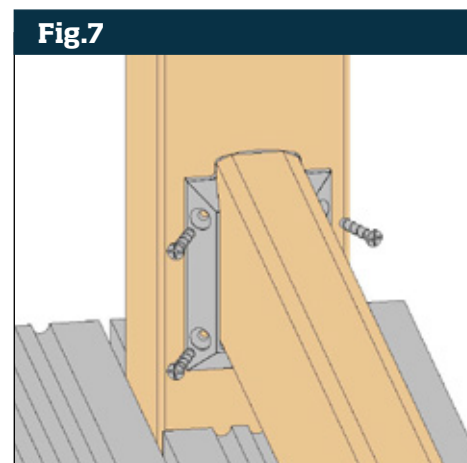
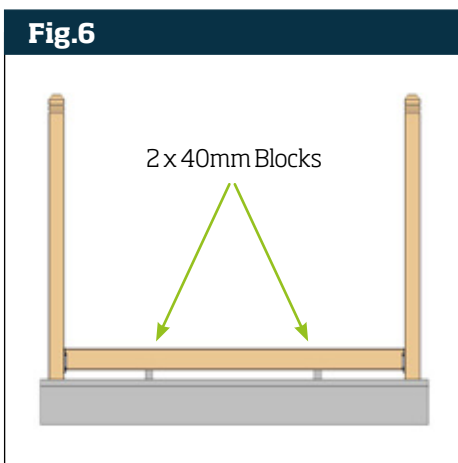
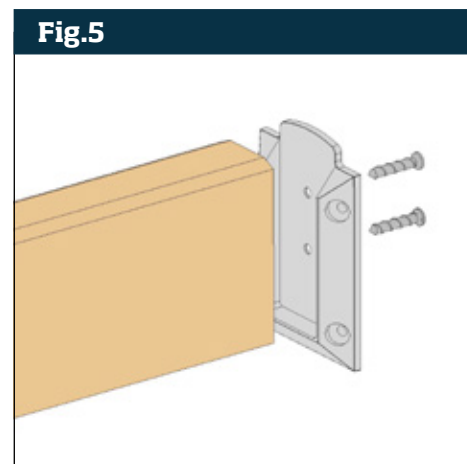
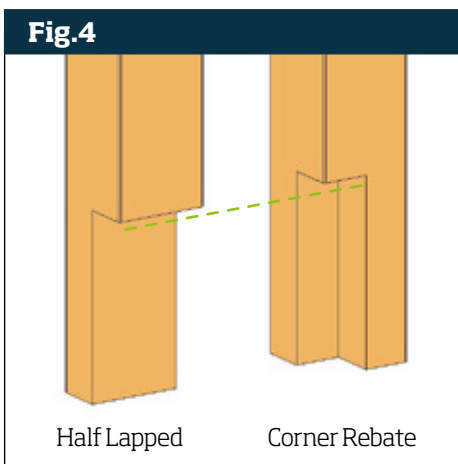
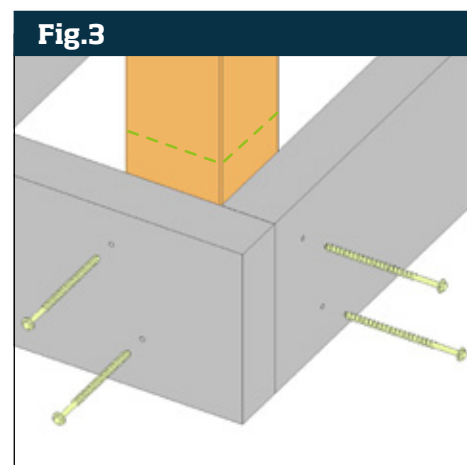
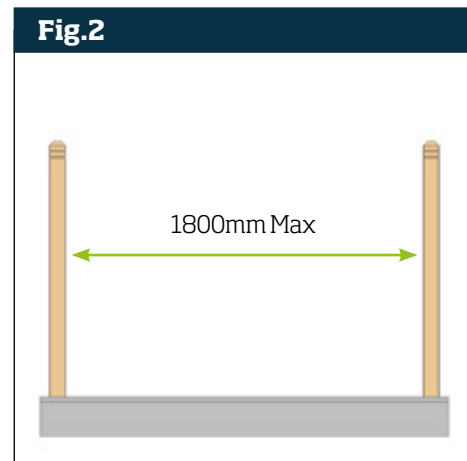
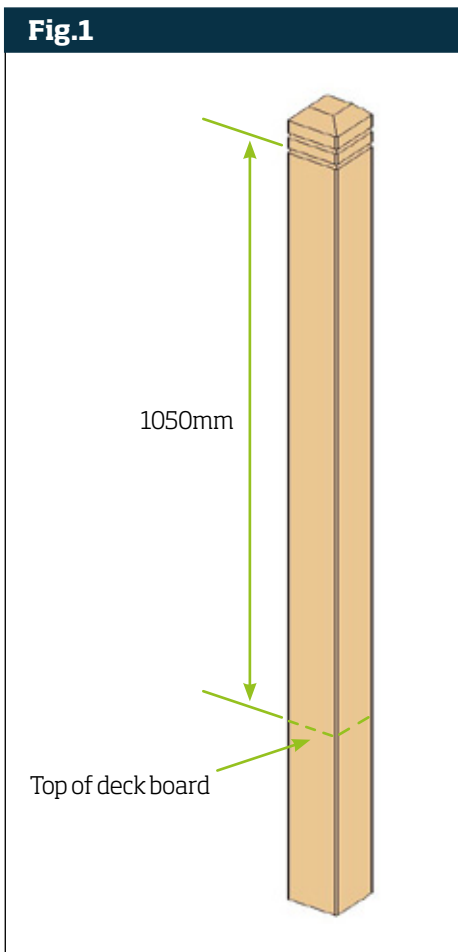

Offer rail hanger brackets to each end of the top rail. Pilot drill through back bracket holes and secure with screws supplied. Draw a horizontal line 30mm down from top of top rail to approx. 50mm long. This will be used to set height of top rail to spindle tops (Fig.8).

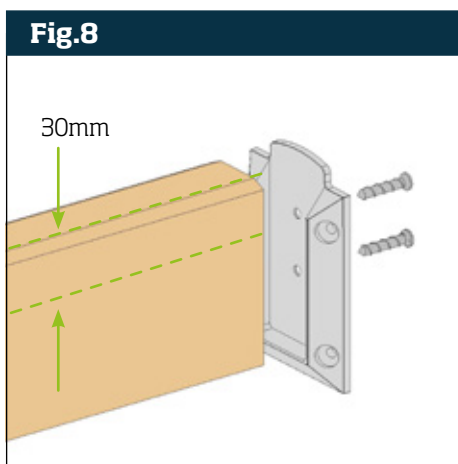

Place a spindle up against bottom rail at each end, next to rail hanger brackets, with the chamfer end at the top and the flat spindle end at the bottom, flush with the underside of the bottom rail. Temporarily clamp in place.

Offer top rail assembly between posts so that the 30mm line runs flush with the tops of both spindles (Fig.9).

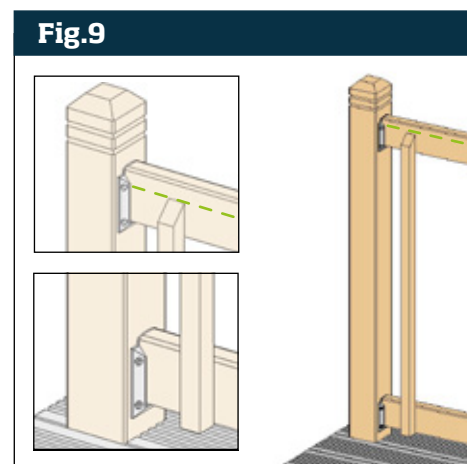

Centre the top rail hanger brackets to the post face. Pilot drill through side bracket holes and fix to post using screws supplied (Fig.10). Unclamp spindles and remove.

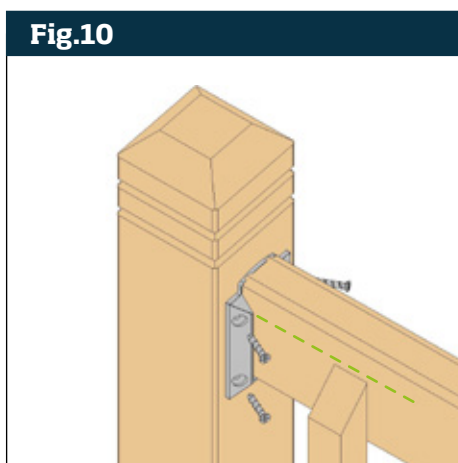

Inserting spindles

Measure distance between inside post faces (Fig.11).

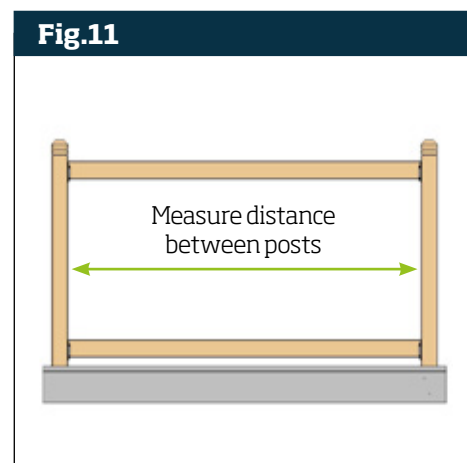

To establish number of spindles and spacings -

- Divide distance between posts by 121. Round to nearest whole number to get spindles required.
- Multiply this number by spindle width.
- Subtract this number from distance between posts.
- Divide by number of spindles (plus 1) to establish spindle gaps.

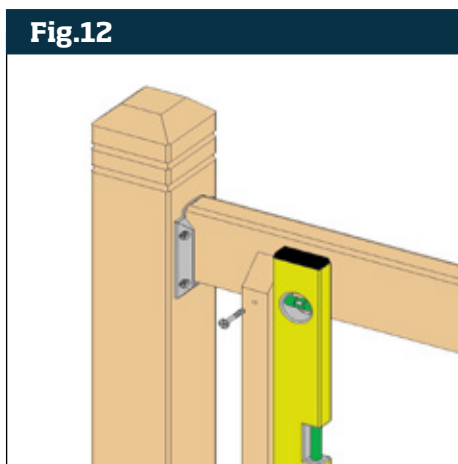

Example

- Distance between posts = 1800mm
- Divide distance by 121 ($1800/121 = 14.8$) Round to nearest whole number = 15 spindles
- Multiply no of spindles by spindle width, 15 spindles x 32mm wide = 480mm
- Subtract number from distance between post, $1800 - 480 = 1320$ mm
- Number of spindles is 15 plus 1 = 16, $1320\text{mm}/16 = 82.5$ mm gap between spindles

Please note if gap is bigger than 99mm, add another spindle and recalculate.

Offer spindle to top and bottom rail, ensuring bottom flat end of spindle is level with underside of bottom rail. Set to established gap size and check it is vertical using a spirit level. Pilot drill through top and bottom of spindle and secure to rails using suitable screws (not supplied) (Fig.12). Repeat for all spindles

Cut capping rail to length and offer over top rail. Pilot drill through top of capping rail and secure with suitable screws (Fig.13).



CHESHIRE
mouldings
TRADE

Technical Helpline:
Freephone
0800 085 3475