



Core Deck Turned Softwood Fitting Instructions



DESIGNED BY FITTERS FOR **EASY INSTALLATION**

Important Information

The following instructions are for installing the Cheshire Mouldings **Core Deck Turned Softwood decking system**.

Cheshire Mouldings **Core Deck Turned Softwood decking system** is suitable for **ground level decks** and **decks up to 600mm** above ground level.

Maximum distance between post centres is **2400mm**.

Cheshire Mouldings Core Deck softwood system has been independently tested by FIRA and when installed in accordance with these instructions, conforms with Building Regulations for balustrades at 900mm (min) high and 0.36KN/m domestic loadings.

As only official Cheshire Mouldings parts have been tested, the use of non Cheshire Mouldings products used in conjunction with this system cannot be guaranteed to conform.

All components should be inspected BEFORE installation commences for any damage and to check all your items are correct before installation. While care is taken to match our engineered timber products, timber is a natural product where the colour, grain structure, can vary.

While we do everything possible to ensure the information contained within these fitting instructions are correct, they are only a general guide, every situation is different. Please read through the fitting instruction fully before commencing any fitting, Cheshire Mouldings will not be held responsible for any mistakes made through incorrect fitting. You will need to take extra care when installing pre-finished components and some touching up will undoubtedly be necessary around the cut areas.

If you have any queries please contact our technical helpline on **(0800) 085 3475**

Please note:

All components should be inspected BEFORE installation commences for any damage, as Cheshire Mouldings cannot be held responsible for any damage caused during installation

Tools required:

Saw, Battery drill, pozi-drive bit, 6mm hexagon drive bit, drill bits \varnothing 3mm, \varnothing 10.5mm, \varnothing 16mm, hammer, chisel, spirit level, tape measure, square.

Download our Interactive Wall Panel Collection Brochure

Includes lots of new Clickable content



Sign up for our New Trade App



Fitting Instructions

Installing Posts

To establish correct height and length for the posts, first take 2 handrail lengths and lay one on top of the other and offer up to middle of newel post head. Mark position of top and bottom of the rail assembly (**Fig.1**).

Now measure down 920mm from top handrail line and mark. This indicates top of deck board level. Transfer all lines across to remaining decking posts (**Fig.2**).

Posts should be positioned no greater than 2400mm between centres.

Secure your post at the correct height with 100mm landscape screws by either positioning the posts inside the joists so that 2 post faces can be secured through 2 joists at 90° (**Fig.3**). If this is not possible, posts that are fitted to the outside of the joists should be half lapped to the height of the joist and deck board thickness and rebate any corner posts if the balustrade has a 90° turn (**Fig.4**).

Handrails

With posts secured, re-measure distance between inside post faces (**Fig.5**). Trim top handrail assembly and single bottom rail to length.

Place 2 x 40mm blocks onto top of deck boards and offer single bottom rail between posts and onto top of blocks (**Fig.6**). Mark position of top of bottom rail on the post (**Fig.7**).

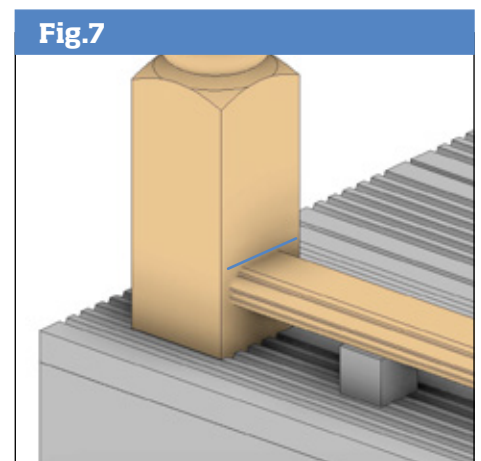
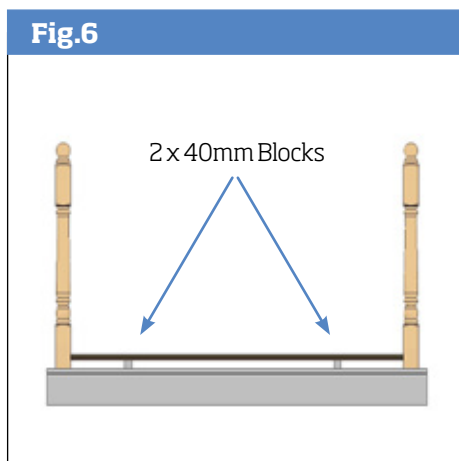
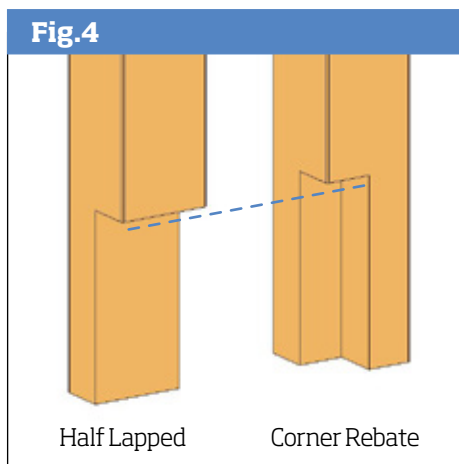
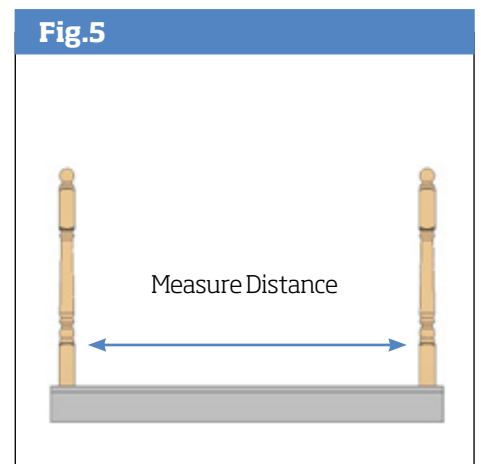
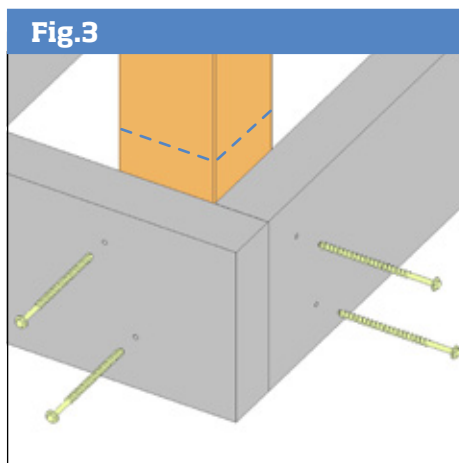
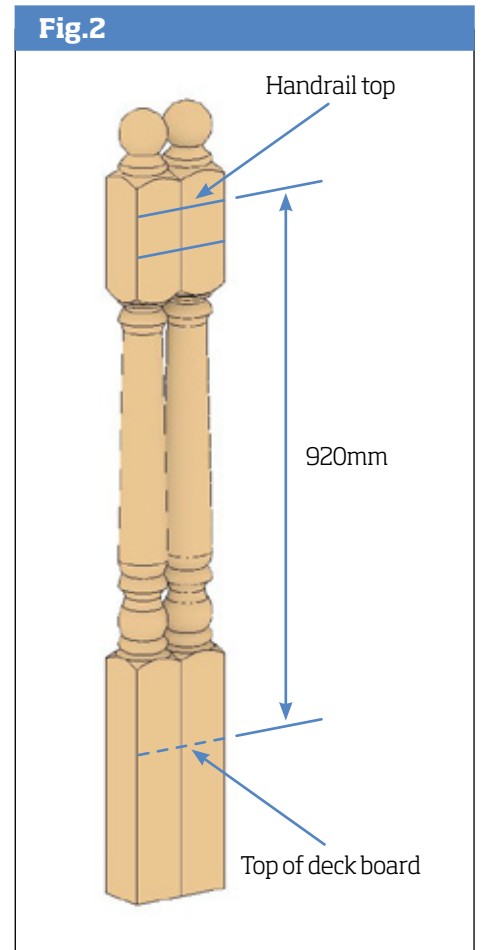
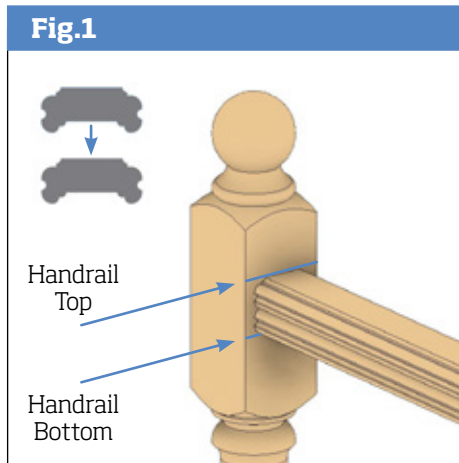

Remove bottom rail and fix Deckit brackets to each end on the underside of rail in the rebate. Ensure that the brackets are positioned centrally and that the square shoulders of the brackets are set flush with the rail ends. Pilot drill through the bracket holes and fix using No 8 x 19mm screws supplied (**Fig.8**).

Repeat procedure on one of the top handrail lengths.

To establish spindle lengths, measure distance between bottom mark of top handrail and top of bottom rail mark (**Fig.9**). Cut spindles to length.

Inserting spindles

Measure and mark 95mm from each end of bottom rail and mark. These are centre locations for first and last spindles -

To establish remaining spindle centres -

- Measure distance between first and last centre marks.
- Divide by 120 and round figure to next whole number.
- Divide distance by whole number.

Example

- Distance between first and last centre marks = 1610mm.
- $1610 \div 120 = 13.4$ rounded up to 14.
- $1610 \text{mm} \div 14 = 115 \text{mm}$ centres.

If centres are greater than 121mm, increase whole number by 1 and recalculate

Mark centre locations to top and bottom rail. Position spindles centrally to centre marks. Pilot drill through rails and secure with No 8 x 75mm stainless steel screws or similar (**Fig.10**).

Place assembled rail/spindle infill between and to front of decking posts and rest on 40mm blocks so that the Deckit brackets are up against the post faces (**Fig.11**). Mark 4 bracket hole centre positions on the newel posts and off set vertical centreline by 2mm.

Transfer the horizontal centreline, using a square, to inside face of posts. Establish and mark centre point of inside faces (**Fig.12**).

On outside face of posts, drill a 10.5mm dia hole to a depth of 60mm for the Deckit fixing bolts. On the inside faces drill a 16mm dia hole to a depth of 40mm to accept the Deckit bracket lugs (**Fig.13**).

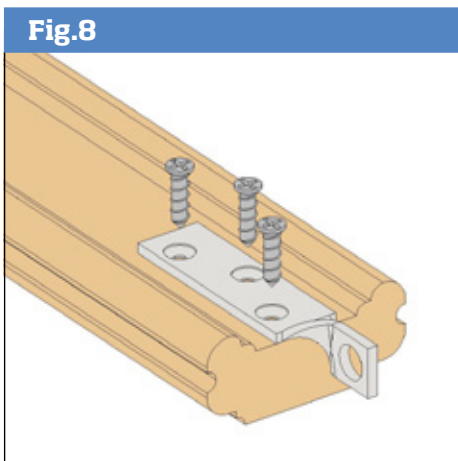

Fig.8

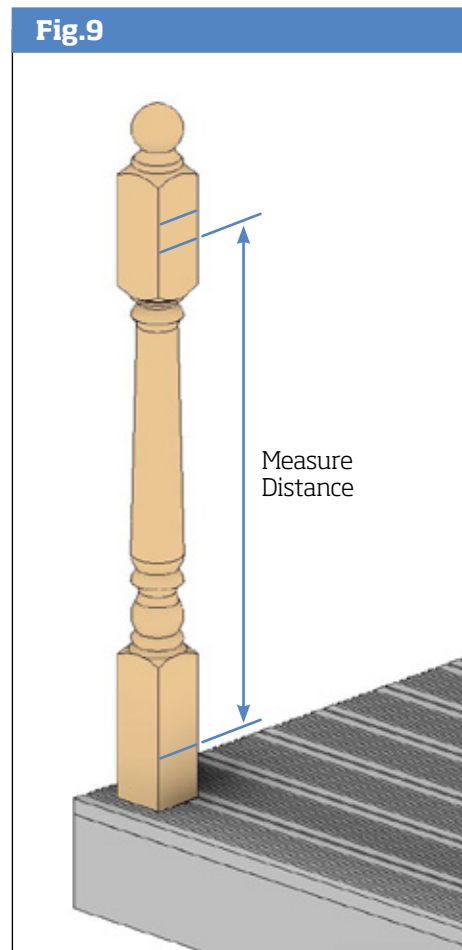

Fig.9

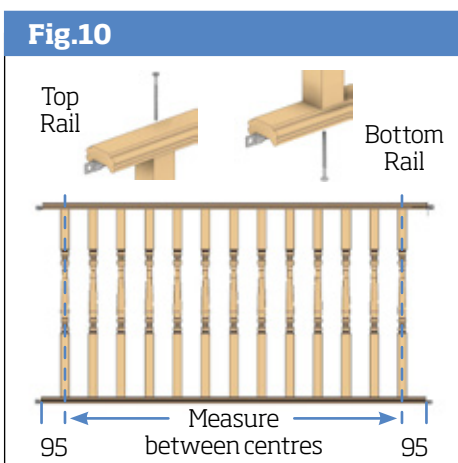

Fig.10

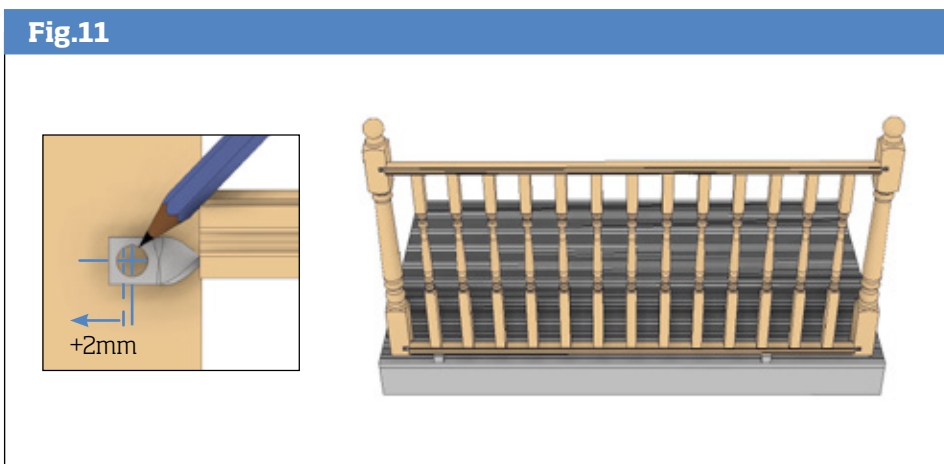

Fig.11

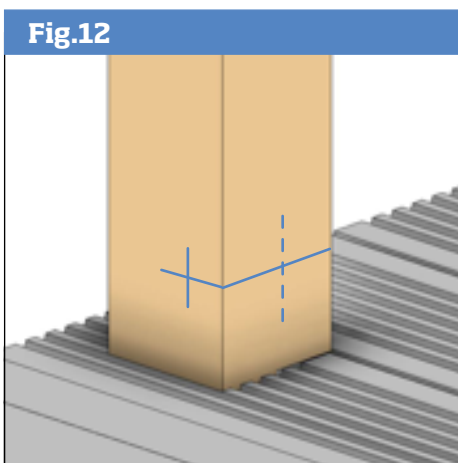

Fig.12

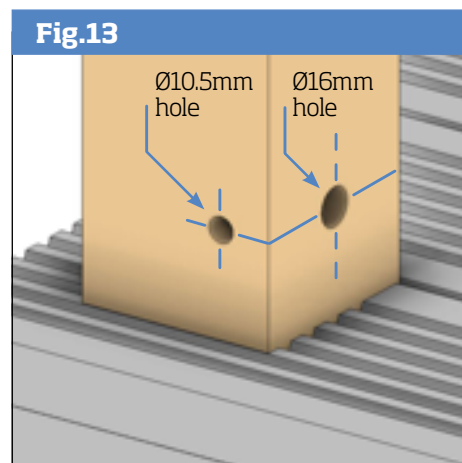

Fig.13

Installing balustrade infill

If the posts are fixed inside the joists (see Fig.3) remove landscape screws and remove both newel posts.

Offer infill assembly to the newel post so the Deckit bracket lugs are inserted into 16mm dia newel post holes.

Insert the Deckit fixing bolts into the 10.5mm dia holes and tighten using a 6mm hexagon drive bit until top and bottom rails are pulled up tight against the newel face (Fig.14). Repeat for newel post at other end.

Align and lower balustrade unit back into original position using the 40mm blocks to rest the bottom rail on (this may require 2 people) (Fig.15). Permanently secure both newel posts with 100mm landscape screws. If the posts are half lapped to the side of the deck (see Fig.4), it is only necessary to remove one post. Offer infill assembly into secured newel post on the deck, resting the bottom rail on 2 x 40mm blocks and tighten using Deckit fixing bolts as above. Then slide the next newel up to the infill and when brackets have been inserted into 16mm dia post holes, secure with fixing bolts until ends of rails are tight against inside post faces.

Permanently fix newel post in place with 100mm landscape screws (Fig.16).

Offer length of rail onto top rail. To fix, drill multiple pilot holes at every 2nd spindle gap, through the underside of the top rail which the spindles are attached to, then screw up through the rail until tight (Fig.17).

To finish, apply timber cover caps to 10.5mm holes using exterior PVA wood glue.

Fig.14

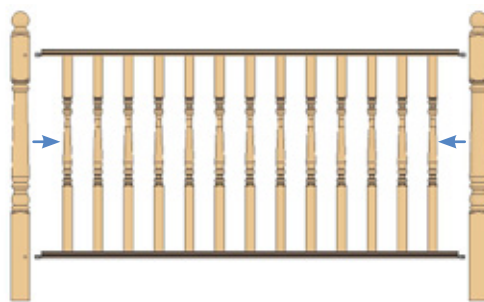
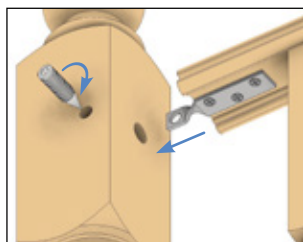

Fig.15

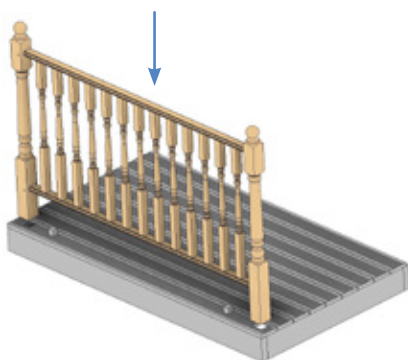

Fig.16

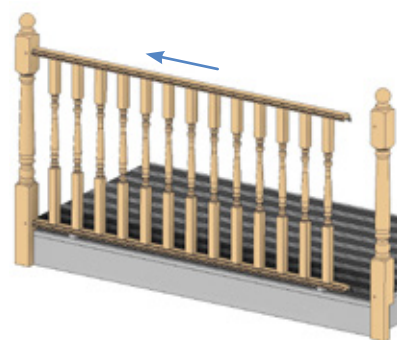
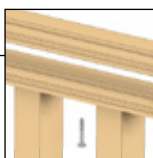
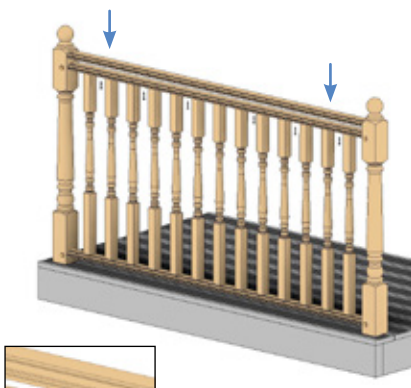

Fig.17



Check out our huge **PRODUCT RANGE**

We supply more than you think



www.cheshiremouldings.co.uk



Technical Helpline:
Freephone
0800 085 3475

