

## Door Casing Set

Fitting  
Instructions



DC102

DESIGNED BY FITTERS FOR **EASY INSTALLATION**



# Important Information

The following instructions are for installing the **Cheshire Mouldings Softwood Door Casing Set**.

## Please note

All components should be inspected BEFORE installation commences for any damage, as Cheshire Mouldings cannot be held responsible for any damage caused during installation. We do not recommend the use of a sharp blade to open the packaging as this may damage the product.

## Tools required

Pencil, tape measure, saw, drill, spirit level, hammer, mastic gun, utility knife, square.

## Kit contents

**A** - Trenched Header x 1

**B** - Door Jambs x 2

Note - fixings are not supplied

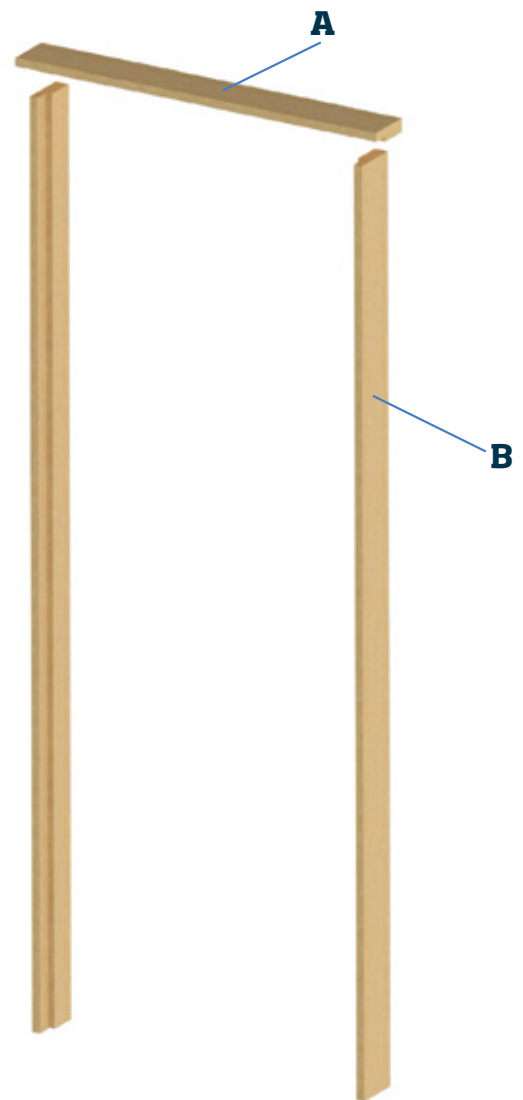

## Download our Interactive **Wall Panel Collection Brochure**

Includes lots of new **Clickable content**



## Sign up for our **New Trade App**



# Fitting Instructions

## Assembling the Frame

Flip the trenched header to suit the width of door being installed. Apply PVA glue to header trench and offer jambs into header. Drill two pilot holes down through the top of the header into each jamb and secure with screws (Fig 1).

Cut header ends so it fits into structural opening. Check your door height and cut the side jambs to suit (Fig 2).

## Fitting the Frame

Fix some scrap timber battens to stabilise the frame, ensuring that the corners are perfectly square and the top and bottom measurements between the jambs are equal (Fig 3).

Offer the assembled frame into the structural opening ensuring that the faces of the frame is flush with the finished wall face (Fig 4).

Apply packers around the frame ensuring the frame header remains level and the jambs perpendicular using a spirit level. A minimum of four packers each side starting approx. 150mm from the top of the frame then 600mm max centres for the remainder (Fig 5). Check all sides are level and vertical.

For the frame fixings, pilot drill through the frame in close relation to the packers and countersink/counterbore the hole (Fig 6). Try to drill centrally to the jamb face. This will stop the frame from distorting when the screws are secured. Check sides are level and vertical and top and bottom measurements between jambs are the same. Adjust where required.

The screws should be inserted into the surrounding wall to a minimum depth of 50mm (Fig 7). Fill and sand screw holes or fill with timber flush pellet.

## Filling Frame to Wall Gap

Once fixed, fill the gap between the frame and structural opening with low pressure expanding foam. Adding the foam improves insulation and reduces drafts. Let the foam expand and dry according to manufacturers instructions.

Once set, cut excess foam flush with a utility knife.

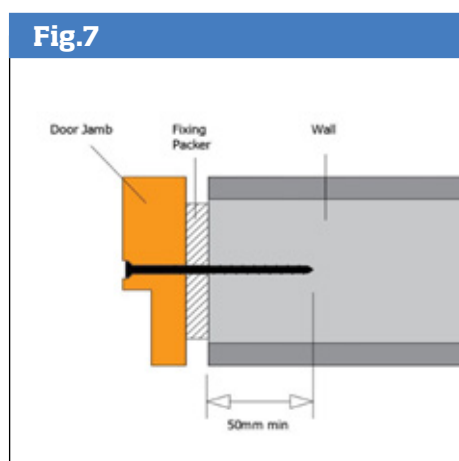
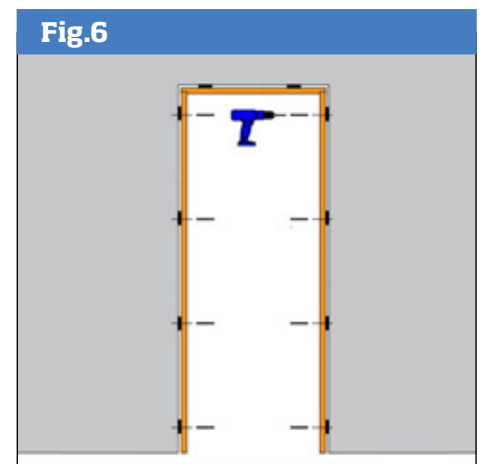
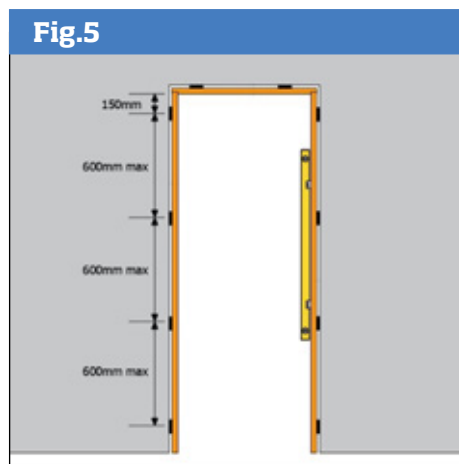
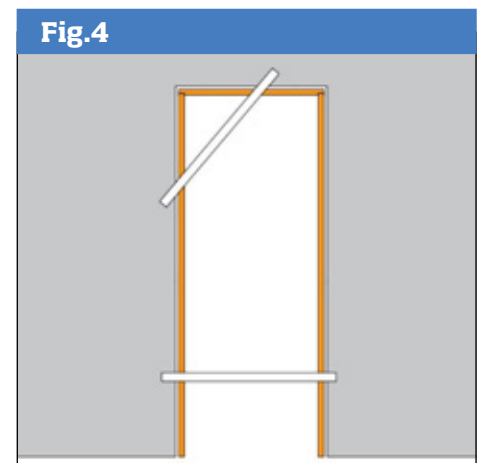
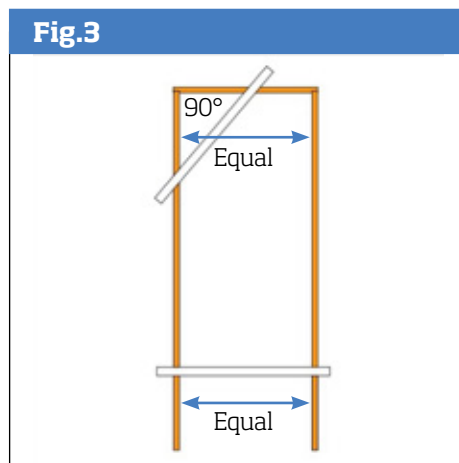
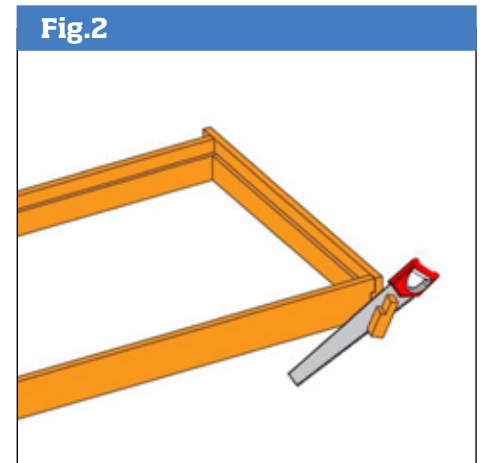
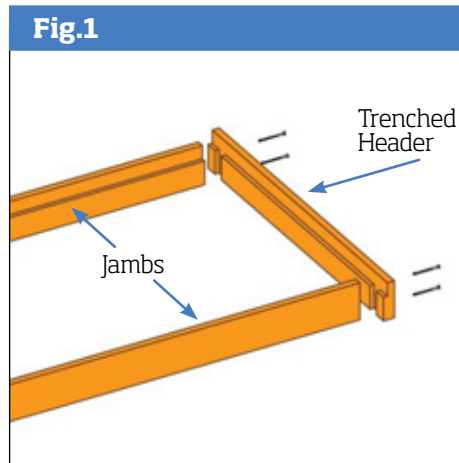

# Check out our huge **PRODUCT RANGE**

*We supply more than you think*



[www.cheshiremouldings.co.uk](http://www.cheshiremouldings.co.uk)



Technical Helpline:  
**Freephone**  
**0800 085 3475**